

Panel mounted signal lamps Ex9IL



- Panel mounted signal lamps
- Tested according to IEC / EN 60947-5-1
- Degree of protection IP65
- Flat and arc shaped head cover types
- Various colour cover variants
- Height 51 or 53 mm
- Easy mounting into standard 22 mm panel cutout
- LED technology
- Compact design

Panel mounted signal lamps Ex9IL are used in various control desks, operator panels, machine control parts, security systems as well as in power distribution boards where it is necessary to show actual status or some event occurring in the circuit. Device's height is 51 or 53 mm (depends on type) only. There are available versions with white, green, red, yellow or blue head colour in two basic design variants. The first one with flat and the second with arc shaped head cover.

Based on the requested application, there are offered two variants according to internal connection, resistance and capacitance types. Used LED lights reduce current consumption, heat dissipation and extend service life.

Type Key

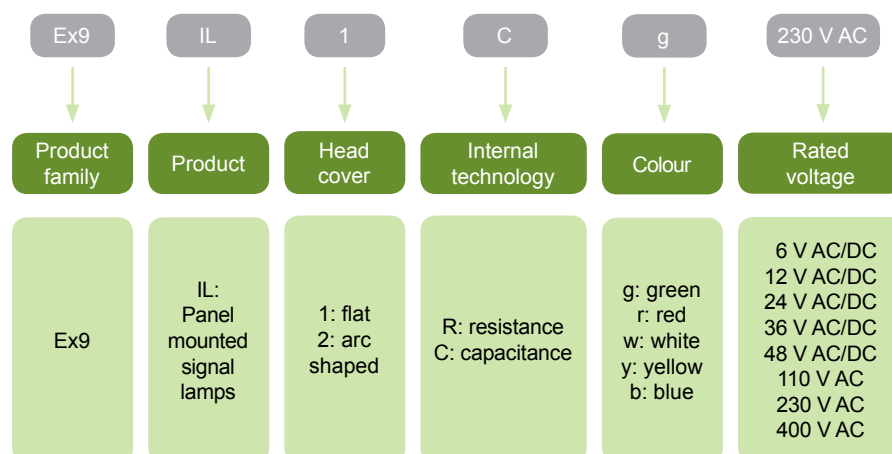

Certification marks



Panel mounted signal lamps Ex9iL

Flat shaped head cover types

- Scope of delivery: complete device consisting of device body, internal LED function block, head cover



Rated voltage	Colour	Technology	Article No.	Type	Packing
6 V AC/DC	white	resistance	105413	Ex9iL 1R w 6V AC/DC	1/10
6 V AC/DC	green	resistance	105414	Ex9iL 1R g 6V AC/DC	1/10
6 V AC/DC	red	resistance	105415	Ex9iL 1R r 6V AC/DC	1/10
6 V AC/DC	yellow	resistance	105416	Ex9iL 1R y 6V AC/DC	1/10
6 V AC/DC	blue	resistance	105417	Ex9iL 1R b 6V AC/DC	1/10
12 V AC/DC	white	resistance	105418	Ex9iL 1R w 12V AC/DC	1/10
12 V AC/DC	green	resistance	105419	Ex9iL 1R g 12V AC/DC	1/10
12 V AC/DC	red	resistance	105420	Ex9iL 1R r 12V AC/DC	1/10
12 V AC/DC	yellow	resistance	105421	Ex9iL 1R y 12V AC/DC	1/10
12 V AC/DC	blue	resistance	105422	Ex9iL 1R b 12V AC/DC	1/10
24 V AC/DC	white	resistance	105423	Ex9iL 1R w 24V AC/DC	1/10
24 V AC/DC	green	resistance	105424	Ex9iL 1R g 24V AC/DC	1/10
24 V AC/DC	red	resistance	105425	Ex9iL 1R r 24V AC/DC	1/10
24 V AC/DC	yellow	resistance	105426	Ex9iL 1R y 24V AC/DC	1/10
24 V AC/DC	blue	resistance	105427	Ex9iL 1R b 24V AC/DC	1/10
36 V AC/DC	white	resistance	105428	Ex9iL 1R w 36V AC/DC	1/10
36 V AC/DC	green	resistance	105429	Ex9iL 1R g 36V AC/DC	1/10
36 V AC/DC	red	resistance	105430	Ex9iL 1R r 36V AC/DC	1/10
36 V AC/DC	yellow	resistance	105431	Ex9iL 1R y 36V AC/DC	1/10
36 V AC/DC	blue	resistance	105432	Ex9iL 1R b 36V AC/DC	1/10
48 V AC/DC	white	resistance	105433	Ex9iL 1R w 48V AC/DC	1/10
48 V AC/DC	green	resistance	105434	Ex9iL 1R g 48V AC/DC	1/10
48 V AC/DC	red	resistance	105435	Ex9iL 1R r 48V AC/DC	1/10
48 V AC/DC	yellow	resistance	105436	Ex9iL 1R y 48V AC/DC	1/10
48 V AC/DC	blue	resistance	105437	Ex9iL 1R b 48V AC/DC	1/10
110 V AC	white	capacitance	105438	Ex9iL 1C w 110V AC	1/10
110 V AC	green	capacitance	105439	Ex9iL 1C g 110V AC	1/10
110 V AC	red	capacitance	105440	Ex9iL 1C r 110V AC	1/10
110 V AC	yellow	capacitance	105441	Ex9iL 1C y 110V AC	1/10
110 V AC	blue	capacitance	105442	Ex9iL 1C b 110V AC	1/10
230 V AC	white	capacitance	105443	Ex9iL 1C w 230V AC	1/10
230 V AC	green	capacitance	105444	Ex9iL 1C g 230V AC	1/10
230 V AC	red	capacitance	105445	Ex9iL 1C r 230V AC	1/10
230 V AC	yellow	capacitance	105446	Ex9iL 1C y 230V AC	1/10
230 V AC	blue	capacitance	105447	Ex9iL 1C b 230V AC	1/10
400 V AC	white	capacitance	105448	Ex9iL 1C w 400V AC	1/10
400 V AC	green	capacitance	105449	Ex9iL 1C g 400V AC	1/10
400 V AC	red	capacitance	105450	Ex9iL 1C r 400V AC	1/10
400 V AC	yellow	capacitance	105451	Ex9iL 1C y 400V AC	1/10
400 V AC	blue	capacitance	105452	Ex9iL 1C b 400V AC	1/10

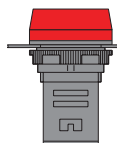

Panel mounted signal lamps Ex9IL

Arc shaped head cover types

- Scope of delivery: complete device consisting of device body, internal LED function block, head cover



Rated voltage	Colour	Technology	Article No.	Type	Packing
6 V AC/DC	white	resistance	105453	Ex9IL 2R w 6V AC/DC	1/10
6 V AC/DC	green	resistance	105454	Ex9IL 2R g 6V AC/DC	1/10
6 V AC/DC	red	resistance	105455	Ex9IL 2R r 6V AC/DC	1/10
6 V AC/DC	yellow	resistance	105456	Ex9IL 2R y 6V AC/DC	1/10
6 V AC/DC	blue	resistance	105457	Ex9IL 2R b 6V AC/DC	1/10
12 V AC/DC	white	resistance	105458	Ex9IL 2R w 12V AC/DC	1/10
12 V AC/DC	green	resistance	105459	Ex9IL 2R g 12V AC/DC	1/10
12 V AC/DC	red	resistance	105460	Ex9IL 2R r 12V AC/DC	1/10
12 V AC/DC	yellow	resistance	105461	Ex9IL 2R y 12V AC/DC	1/10
12 V AC/DC	blue	resistance	105462	Ex9IL 2R b 12V AC/DC	1/10
24 V AC/DC	white	resistance	105463	Ex9IL 2R w 24V AC/DC	1/10
24 V AC/DC	green	resistance	105464	Ex9IL 2R g 24V AC/DC	1/10
24 V AC/DC	red	resistance	105465	Ex9IL 2R r 24V AC/DC	1/10
24 V AC/DC	yellow	resistance	105466	Ex9IL 2R y 24V AC/DC	1/10
24 V AC/DC	blue	resistance	105467	Ex9IL 2R b 24V AC/DC	1/10
36 V AC/DC	white	resistance	105468	Ex9IL 2R w 36V AC/DC	1/10
36 V AC/DC	green	resistance	105469	Ex9IL 2R g 36V AC/DC	1/10
36 V AC/DC	red	resistance	105470	Ex9IL 2R r 36V AC/DC	1/10
36 V AC/DC	yellow	resistance	105471	Ex9IL 2R y 36V AC/DC	1/10
36 V AC/DC	blue	resistance	105472	Ex9IL 2R b 36V AC/DC	1/10
48 V AC/DC	white	resistance	105473	Ex9IL 2R w 48V AC/DC	1/10
48 V AC/DC	green	resistance	105474	Ex9IL 2R g 48V AC/DC	1/10
48 V AC/DC	red	resistance	105475	Ex9IL 2R r 48V AC/DC	1/10
48 V AC/DC	yellow	resistance	105476	Ex9IL 2R y 48V AC/DC	1/10
48 V AC/DC	blue	resistance	105477	Ex9IL 2R b 48V AC/DC	1/10
110 V AC	white	capacitance	105478	Ex9IL 2C w 110V AC	1/10
110 V AC	green	capacitance	105479	Ex9IL 2C g 110V AC	1/10
110 V AC	red	capacitance	105480	Ex9IL 2C r 110V AC	1/10
110 V AC	yellow	capacitance	105481	Ex9IL 2C y 110V AC	1/10
110 V AC	blue	capacitance	105482	Ex9IL 2C b 110V AC	1/10
230 V AC	white	capacitance	105483	Ex9IL 2C w 230V AC	1/10
230 V AC	green	capacitance	105484	Ex9IL 2C g 230V AC	1/10
230 V AC	red	capacitance	105485	Ex9IL 2C r 230V AC	1/10
230 V AC	yellow	capacitance	105486	Ex9IL 2C y 230V AC	1/10
230 V AC	blue	capacitance	105487	Ex9IL 2C b 230V AC	1/10
400 V AC	white	capacitance	105488	Ex9IL 2C w 400V AC	1/10
400 V AC	green	capacitance	105489	Ex9IL 2C g 400V AC	1/10
400 V AC	red	capacitance	105490	Ex9IL 2C r 400V AC	1/10
400 V AC	yellow	capacitance	105491	Ex9IL 2C y 400V AC	1/10
400 V AC	blue	capacitance	105492	Ex9IL 2C b 400V AC	1/10

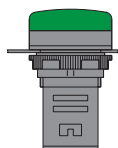

Panel mounted signal lamps Ex9IL

Spare flat shaped head covers



Colour	Article No.	Type	Packing
white	105403	Ex9IL 1 w	1/20
green	105404	Ex9IL 1 g	1/20
red	105405	Ex9IL 1 r	1/20
yellow	105406	Ex9IL 1 y	1/20
blue	105407	Ex9IL 1 b	1/20

Spare arc shaped head covers



Colour	Article No.	Type	Packing
white	105408	Ex9IL 2 w	1/20
green	105409	Ex9IL 2 g	1/20
red	105410	Ex9IL 2 r	1/20
yellow	105411	Ex9IL 2 y	1/20
blue	105412	Ex9IL 2 b	1/20

Position and function description labels

- Various versions of labels
- Holder and labels to be ordered separately
- Silver plastic material of stickers
- Self-adhesive - can be stuck onto the holder or inserted underneath of transparent cover
- Printing colour of standard and customer defined labels: black
- Customer defined variants of labels (ordering quantity as multiple of 7 pcs, printing can be different for every single piece)*



Description	Article No.	Type	Packing
Holder for labels	106776	Ex9P1 S SH	1

Label printing	Article No.	Type	Packing
Empty label (25x11 mm)	106777	Ex9P1 S S0	10
OFF - ON	106778	Ex9P1 S S1	10
0 - I	106779	Ex9P1 S S2	10
I - 0 - II	106780	Ex9P1 S S3	10
STOP - START	106781	Ex9P1 S S4	10
0 - 1	106782	Ex9P1 S S5	10
1 - 0 - 2	106783	Ex9P1 S S6	10
STOP	106784	Ex9P1 S S7	10
START	106785	Ex9P1 S S8	10
ON	106786	Ex9P1 S S9	10
OFF	106787	Ex9P1 S S10	10
RUN	106788	Ex9P1 S S11	10
AUTO	106789	Ex9P1 S S12	10
FAULT	106790	Ex9P1 S S13	10
Customer defined printing*	107876	Ex9P1 S S_USER	7

**) Ordering of customer defined stickers:*

- Order the item 107876
- Attach the information with requested sticker text and quantity of stickers with given content. Each sticker can be different
- Minimum ordering quantity is 7 pieces and multiples
- In case of graphic symbol to be produced, it is necessary to deliver source data (pdf, ai, jpg, png, etc.)
- Mention positioning of the sticker (standard horizontal, vertical)
- Maximum printable area is 10 x 24 mm (H x W)

Technical Data Ex9IL

Panel mounted signal lamps

General parameters

Suitable for signaling of status of circuit in industrial applications, security system, etc.
Flat and arc shaped head cover types
Device height 51 or 53 mm (depends on type)
LED technology

Electrical parameters

Tested according to	IEC / EN 60947-5-1
Rated operational voltage U_e	6, 12, 24, 36, 48 V AC/DC (resistance types) 110, 230, 400 V AC (capacitance types)
Rated operational current I_e	≤ 20 mA
Rated frequency f	50/60 Hz
Rated impulse withstand voltage U_{imp}	2.5 kV
Rated insulation voltage U_i	400 V
Electrical service life	$\geq 30\,000$ hours
Power consumption	< 1 W
Brightness	≥ 60 cd/m ²

Mechanical parameters

Mounting	into standard 22 mm panel cutout
Mounting position	arbitrary
Degree of protection	IP65 (IP20 terminals)
Terminals	lift
Terminal capacity	0.5 — 2.5 mm ²
Fastening torque of terminals	0.8 Nm
Ambient temperature	-5 — +40 °C
Altitude	≤ 2000 m
Relative humidity	≤ 90 % at 20°C
Pollution degree	3
Installation class	II
Overvoltage category	III
Comparative tracking index CTI	175 V

Technical Data Ex9IL

Panel mounted signal lamps

Dimensions

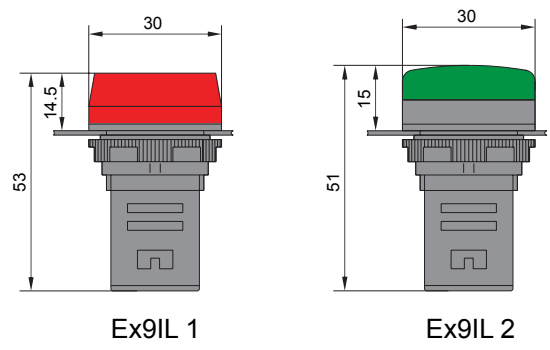

Mounting

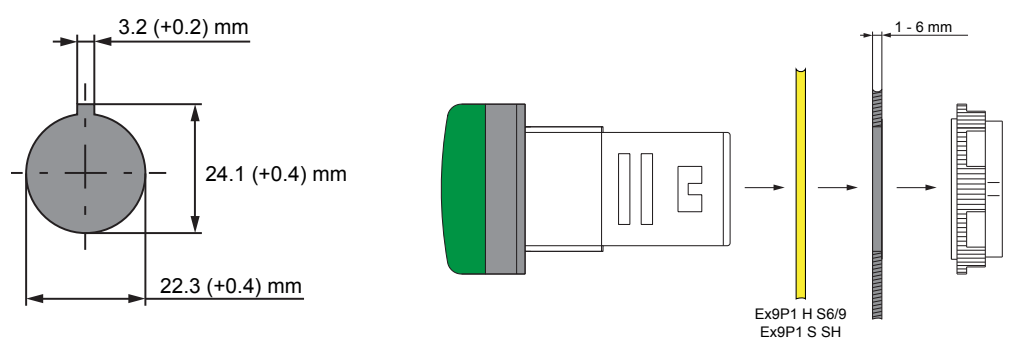

Wiring diagram

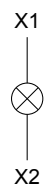

Dimensions (holder for labels)

