

**Material:**

- Housing: Zinc die-cast, chrome plated or black powder coated.
- Cylinder: Zinc die-cast, stainless steel cap and dust shutter.
- Nut: Zinc die-cast, zinc plated.
- Screw and cam: Steel, zinc plated.

**Notes, Tests:**

Cams may be chosen with H-measurement between H=04 mm and H=50 mm in increments of 2 mm (4, 6, 8, 10, 12...up to 50 mm). Example: 241535-090-3845 is a black latch, keyed alike with cylinder IL 101, earthing nut, 90° cam rotation and a H-measurement of 38 mm and a standard cam length of 45 mm.

The master key system (marked with \*) is supplied on request only.

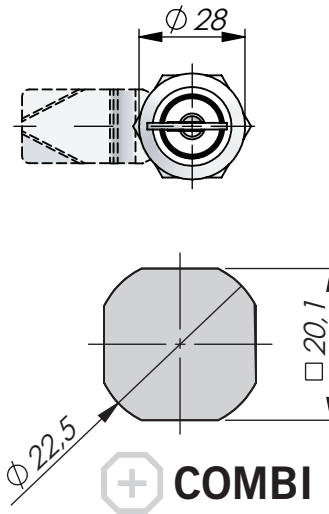

Quarter-turn cylinder lock. Universal clockwise or counter-clockwise rotation when opening / closing. Supplied with nut. Protection degree IP54.

For cams that rotates 90°, the key can be removed in the locked position.

For cams that rotates 180°, the key can be removed in both open and locked position.

Supplied with two keys.

**Cylinder Lock 18 mm (AAAAA-BBB-HHLL)**

AAAAA-	Surface treatment	Cylinder	Nut	BBB	Cam rotation	-HHLL	Cam size in mm
241334-	Chrome	Keyed alike, IL 101	Standard	180	180°	-0000	No cam
241534-	Black	Keyed alike, IL 101	Standard	090	90°	-HH45	See cam ref. above.
241335-	Chrome	Keyed alike, IL 101	Earthing nut				H between 4-50 mm in increments of 2 mm
241535-	Black	Keyed alike, IL 101	Earthing nut				
241336-	Chrome	Keyed to differ	Standard				
241536-	Black	Keyed to differ	Standard				
241337-	Chrome	Keyed to differ	Earthing nut				
241539-	Black	Keyed to differ	Earthing nut				
241336-HNS- *	Chrome	Master key system*	Standard				
241536-HNS- *	Black	Master key system*	Standard				