

Stringing wheel ST157

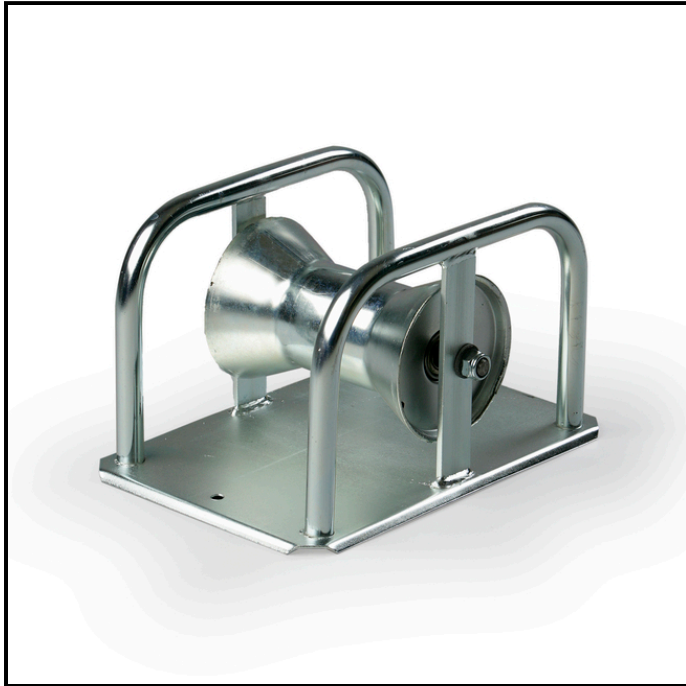

Cable pulling through wheel for underground cables.

Code ST157

GTIN 6418677408328

Name Stringing wheel
Cable pulling through wheel for underground
cable

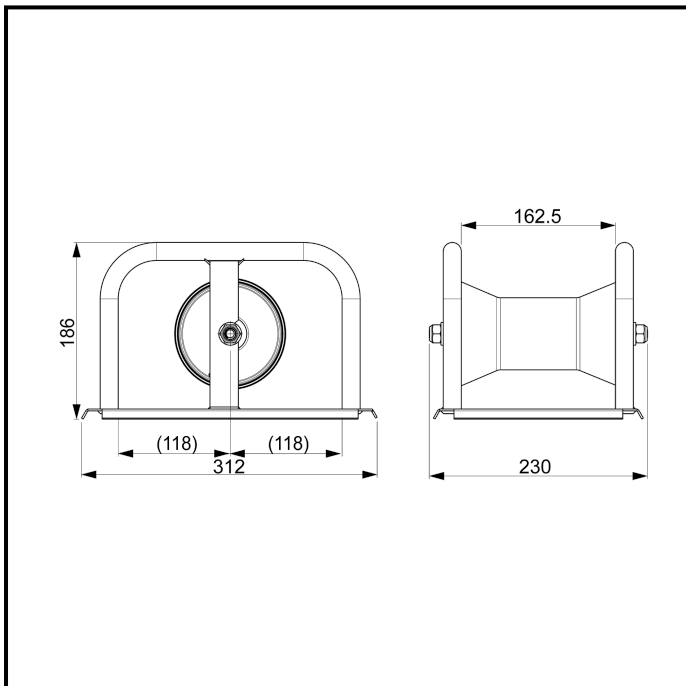

Dimensions

Weight	3.81 kg
Groove diameter	180 mm

Environmental impact

RoHS status	Incomplete
-------------	------------

ETIM

ETIM Class	EC003007
Type of accessory/spare part	Other

Packaging

Plastic bag

Size	1 pce
Weight	3.835 kg

Pallet package

Size	30 pcs
Depth	1200 mm
Height	770 mm
Width	800 mm
Weight	135.050 kg
Volume	739.2 l

Downloads

Dimensional drawing

File type: PDF

